

INTRODUCTION

Thank you for choosing Tornado Industrial Vacuum Cleaner, a high-quality product based on the newest state-of-the-art technology. We hope that this device will be to your satisfaction and meet your expectations. We are continuously striving to improve our products in our product segment and will continue to supply the market with new equipment.

NOTICE!

1. These instructions are only for TIV1000/TIV2000/TIV3000 Dust Extractors.
2. The TIV1000/TIV2000/TIV3000 Dust Extractors are designed to clean construction areas and be connected to small electrical machines such as drills, grinders etc. The machine is suitable for picking up dry, non-flammable dust and debris in an indoor environment. It is not suitable for picking up liquids.
3. Please pay particular attention to the safety regulations and safety instructions
4. Read the complete instruction manual before using.
5. All spare parts and accessories used with this device must be those specified by Tornado.
6. Check before and after use that all the switches are in OFF position.

Environmental protection

The packaging material can be recycled. Please do not throw the packaging material into household waste; please send it for recycling.

Old devices contain valuable materials that can be recycled; these should be sent for recycling. Batteries, oil, and similar substances must not enter the environment. Please dispose of your old devices using appropriate collection systems.

1. SAFETY INSTRUCTIONS

When using an electrical appliance, basic precautions should always be followed, including the following:

WARNING – To reduce the risk of fire, electric shock or injury:

- Cables damaged through crushing or splitting can be dangerous if used and should be replaced immediately. Risk of personal injury.
- Make sure the assembly area is firm, so the dust extractor does not tip over. Risk of personal and material injury.
- Risk of pinching when handling the toggle fasteners.
- The machine must not be used in environments where explosive gases may be present. Serious risk of explosion.
- Improper connection of the equipment-grounding conductor can result in a risk of electrical shock. Check with a qualified electrician or service person if you are in doubt as to whether the outlet is properly grounded. Do not modify the plug provided with the machine. If it will not fit the outlet. Have a proper outlet installed by a qualified electrician.
- Before using the machine, make sure that the power & voltage corresponds with the voltage shown on the machines rating plate.
- Do not leave machine when plugged in. Unplug cord from outlet when not in use and before cleaning or servicing machine.
- Do not use outdoors or on wet surface, this machine is for indoor and dry use only.
- Do not allow to use as a toy. Close attention is necessary when used by or near children.
- Use only as described in this manual. Use only manufacturers recommended attachments.
- Operators shall be adequately instructed on the use of the machine
- This machine is not intended for use by persons (including children) with reduced physical, sensory or mental capabilities, or lack of experience and knowledge.
- Do not use with damaged cord or plug. If the machine is not working as it should, has been dropped, damaged, left outdoors or dropped in water. Make sure it is repaired by a qualified person.
- Do not pull or carry by cord, use cord as handle, close a door on cord, or pull cord around sharp edges or corners. Do not run the machine over cord. Keep cord away from heated surfaces.
- Do not unplug by pulling on cord. To unplug, grasp the plug. Not the cord.
- Do not handle plug or machine with wet hands.
- Regularly inspect cord and plug for damage. If cord is damaged, it must be replaced by a qualified person in order to avoid hazard.
- Do not put any object into openings. Do not use with any opening blocked (accept during filter cleaning procedure). Keep free of dust, hair and anything that may reduce airflow.
- Keep hair, loose clothing, fingers and all parts of body away from openings and moving parts.
- Turn off all controls before unplugging.
- Do not use to pick up flammable or combustible liquids, such as gasoline, or use in areas where they may be present.
- Do not pick up any type of liquids.
- Do not pick up anything that is burning or smoking, such as cigarettes, matches or hot ashes.
- Use extra care when cleaning on stairs.
- Do not use without dust bag and/or filters in place. Replace collection system and/or filters as described in manual.
- If using an extension cord make sure the cord rating is suitable for this machine.
- Do not modify machine from its original design.
- Keep children and unauthorized persons away from machine when in use.
- All repairs must be performed by a qualified service person. Use only manufacturer-supplied or equivalent replacement parts.
- Do not expose machine to rain or moisture. Store indoors only.
- Connect to a properly grounded outlet only. See grounding instructions.

THERMAL PROTECTION

The dust extractor is equipped with a safety thermal protector to prevent motor from overheating. Should thermal protector activate, turn off machine, unplug power cord and check for full dust bag, vacuum hose clog or filter blockage. It may take up to 45 minutes for the thermal protector to reset.

GROUNDING INSTRUCTION

The dust extractor must be grounded. If it should malfunction or breakdown, grounding provides a path of least resistance for electric current to reduce the risk of electric shock. The dust extractor is equipped with a cord having an equipment-grounding conductor and grounding plug. The plug must be inserted into an appropriate outlet that is properly installed and grounded in accordance with all local codes and ordinances.

SAFETY LABEL

The following label appears on the machine, next to the machines rating plate. Replace label if it is missing, becomes damaged or illegible. Failure to follow this warning label may result in fire, electric shock or injury.

2.UNPACKING

When unpacking the machine, please check that the following accessories are included:

- ✓ The hose with end fittings
- ✓ Wand
- ✓ Floor brush

If any of the above-mentioned parts are missing, please contact your local distributor or our sales representative. For models that do not already have the front casters assembled due to packaging limitations. Assemble the front casters using the using bolt or nut and washer that are included in the package depending on your application. Protect the environment:

Please dispose of packaging materials and used machine components in an environmentally safe way according to local disposal regulations. Always remember to recycle.

To assemble the accessories:

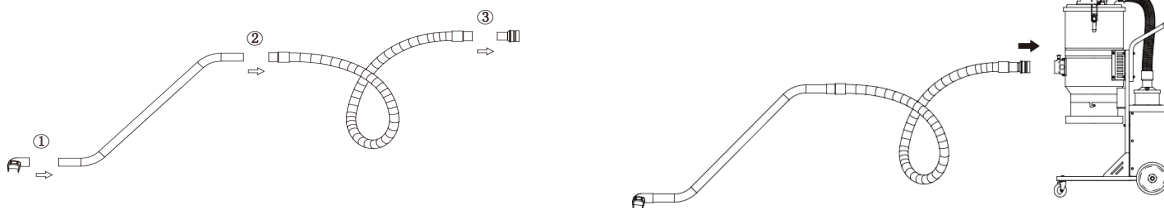

1. Connect the floor brush and wand
2. Connect the Wand and hose
3. Connect the hose and adaptor
- 4 . Connect the accessories kit and the inlet

Note: Don't rolling or twisting the hose when working.

3. FUNCTION

The machine is designed for vacuuming and separating dry, non-combustible dust with an explosion limit value of 0.1 mg/m³.

The dust extractor is started by the switch. **All the switches can operate independently.**

Type	Models with Jet pulse filter cleaning
Red switch 2 step	0: Motor off, 1: Motor on



Notice ! ! !

Before connecting the power, please confirm the voltage is consistent with the label on the machine.

- Make sure the electric plug and socket are matching
- Make sure the hose and inlet are matching
- Connect the accessories and hose end



Notice ! ! !

- Turn on the machine until the motor stop working completely.
- Please disconnect the plug when the machine doesn't work.

Dust-laden air is then sucked through the inlet valve at high speed via the suction hose. The air is slowed down by the cyclone and coarse dust particles are separated out, partly by centrifugal force and partly by gravity. Air and finer particles then pass through the double filter system where separation is made. The machine is designed for filter cleaning by reverse air pulse.

The separated dust accumulates in the cyclone until the machine is switched off, when it drops through the bottom flap into the plastic bag. The filter cleaning process is not completed before it is clear that the dust inside the tank has fallen down into the collection bag. In some extreme cases the adhesive ability of the dust must be broken manually. This can be done by hitting the dust through the bag or tapping the tank using i.e. a rubber hammer.

Automatic start function: When you use the dust extractor together with another machine, there is an electrical outlet on the dust extractor. Connect the machine to this outlet. Then when you start it up the dust extractor will also start after approx. 1-2 seconds. When you turn it off, the dust extractor will continue to run for approximately 10 seconds. To empty the hose. Then stop

4. HEIGHT ADJUSTMENT

TIV2000/TIV3000 WITH HEIGHT ADJUSTMENT SYSTEM:

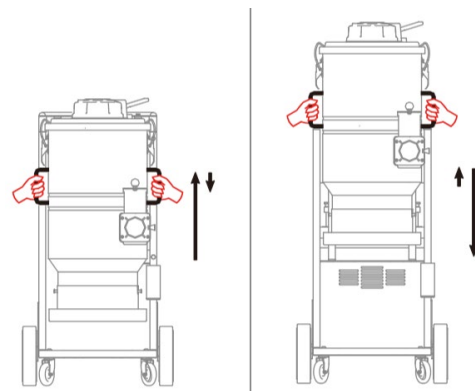

Lifting operating:

Grip the 2 handles on barrel, lift to the top and then loose the grip slowly.

Dropping operating:

Grip the 2 handles on barrel, lift to the top, hold for one second, then drop it down to the bottom.

Lifting

Dropping

5. FILTER CLEANING

The filter must be cleaned from time to time. This must be done before changing the bag collection system and should also be done when work is completed or when there is poor suction.

Procedure:

1. Push the damper to the left, cover the inlet.
2. Turn on the machine and wait 3 seconds, let the machine build up vacuum.
3. Quickly push down on the key and wait 3 seconds.
4. Repeat the procedure five times.
5. Turn off the motor and wait until it stops completely, then uncover the inlet.

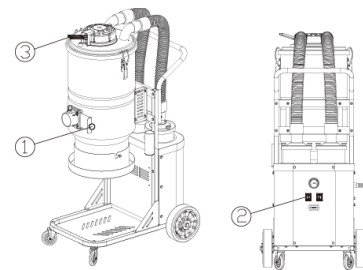

!!! It is important to let the machine rebuild the vacuum in between every repetition.

If suction remains poor, the pre-filter needs to be replaced. If suction still remains poor afterwards, the HEPA filters needs to be replaced. See instructions in chapter 6. FILTER CHANGE.

6. DUST STORAGE SYSTEM

The dust extractors are mainly equipped with continuous folding bagging system for effective dust storage or a regular plastic bag system depending on model. The continuous bag is a 22 m long plastic tube that will be divided into plastic bags using the zip ties attached with the machine.

To assemble a new continuous bag:

Release the belt holding the last bag. Remove the holder, put in a new bag & pull out the inner end upwards. Assemble the holder on to the machine and strap the opening facing upwards with the belt. Pull down the outside end and close it using a zip tie.

All dust extractors can be used with continuous folding dust bags for single use. Also all models can be fitted with the continuous bag system.

Only change continuous bag or regular bag after filter cleaning cycle have been completed.

To operate the continuous bag:

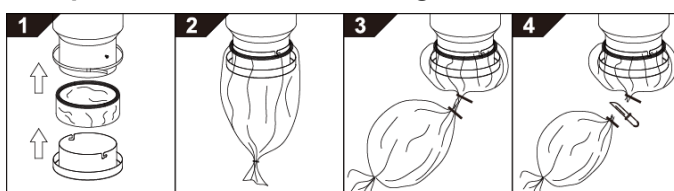

1. Assemble the continuous bag, turn on the machine.
2. Turn off the machine, the dust will drop down to the bags.
3. Use a nylon tie to seal the bag
4. Cut the bag

7. FILTER CHANGE

Risk of dust dispersion - Use personal safety equipment

Unhealthy dust can be spread during filter change. Accordingly, the user should wear protective glasses, protective gloves, and a breathing mask conforming to protection class FFP3.



WARNING

Remember to switch off the machine and pull the plug out of the outlet before servicing.

Pre-filter

Loosen the 3 clamps and remove the top. Take the bag from the new filter.

Lift out the filter and place it gently in a plastic bag. This bag must be properly disposed. Insert a new filter.

Important:

If you are removing the Pre-filter in order to clean it. Hitting the filter with force or use of compressed air will destroy the filter. It can handle water, but high pressure water cleaning will destroy it.

HEPA Filter

Must only be serviced by certified personnel. Carefully lift the filter into a clean plastic bag, use the bag from the new filter. This bag must be properly disposed. Insert a new filter in reverse order.

Important:

HEPA filters can't be cleaned, trying this might destroy it. When installing the replacement filter, make sure to not touch the inside of the filter. Any kind of force/damage on the inside of filter media will destroy the new filter.

8. SERVICE

- When cleaning and servicing the machine, you must switch off the machine and remove the plug from the outlet.
- Avoid cleaning with a high pressure cleaner. If necessary, do not direct at the openings on the machine, especially the opening for cooling air.
- Before moving the machine from the work area, the machine must be cleaned.
- All other equipment must be regarded as contaminated and be treated thereafter.
- If possible, use a special suitable room.
- Proper personnel protective equipment must be used. Dust can be spread when the coarse filter and the absolute filter are replaced that can be hazardous to health. Accordingly, the user should wear protective glasses, protective gloves, and a breathing mask conforming to protection class FFP3.
- All parts which are contaminated after service must be properly disposed of in plastic bags according to all regulations.
- If the machine has to be used for other purposes, it is extremely important that the machine is cleaned, to avoid the spread of hazardous dust.
- Do not puncture the HEPA filter. Risk of dust dispersion.

9. WARRANTY

All Tornado devices and accessories have a 12-month factory warranty counting from the manufacturing date on the machine. Do not attempt to repair the suction apparatus without the consent of the manufacturer.

The warranty does not cover defects which are the result of normal wear and tear, negligence, defective use, unauthorized repair or the suction apparatus being connected to the incorrect voltage.

In the event of any complaint, the suction apparatus or an agreed part of it must be returned to us or our authorized representative for warranty examination and for any warranty repair or replacement.

10. PROBLEM SOLVING

The dust extractors are designed and manufactured for severe environments and tasks, but the user must note that the machine must be protected from knocks and blows. Filter, seals, attachments, and connections are carefully adapted and selected with regard to the operator's work environment. Therefore, the operator and service personnel must treat the machine with care in order for it to work correctly for many years.

Issue	Cause	Solution
Motor doesn't start	No Power	Plug in machine
	Cable defective	Replace cable
	Switch defective	Replace switch
	Soft start defective	Replace soft star
Motor stops immediately after starting	Wrong fuse	Connect to correct fuse
	Shortcut in cable/machine	Order service
Motor runs but there is no suction	Hose not connected	Connect hose
	Hose clogged/blocked	Clean hose
	No dust collection bag	Fit dust collection system
Motor runs but poor suction	Hole in hose	Replace hose
	Filter clogged	Clean filter/Replace filter
	Loose top cover	Adjust
	Defective gaskets	Replace affected gaskets
Dust blown from motor	Wrongly assembled or damaged filter system	Adjust/Replace filters
Abnormal noise		Order service



Notice ! ! ! _____

Any other problem please contact Tornado order service

10. TECHNICAL DATA

Data	Unit	TIV1000/120V	TIV1000/230V	TIV2000/120V	TIV2000/230V	TIV3000/120V	TIV3000/230V
Voltage	V	120V	230V	120V	230V	120V	230V
Power (max)	KW	1.2	1.2	2.4	2.4	2.4	3.6
	HP	1.6	1.6	3.2	3.2	3.2	4.8
Current(UL)	A	8	4	16	8	16	12
Airflow (max)	m³/h	200	200	400	400	485	600
	cfm	118	118	236	236	354	285
Vacuum(Max) Water lift(inch)	mbar		220		220		220
	inch	90	90	90	90	90	72
Main hose	Metric (mm)	4mxD38	4mx D38	7.5mx D50	7.5mx D50	10mxD63	10mx D63
	USCS (inch)	13'x 1.5''	13'x 1.5''	24'X2''	24'X2''	32'X2.5''	32'X2.5''
Inlet	Metric (mm)	50	50	70	70	70	70
	USCS (inch)	2''	2''	2.8''	2.8''	2.8''	2.8''
Pre filter EN 779-F8	% @1µm	99.5	99.5	99.5	99.5	99.5	99.5
Pre filter area	Metric (m2)	1.7	1.7	3	3	4.5	4.5
	USCS (ft2)	18	18	32	32	48	48
HEPA filter EN1833-H13	% @0.3µm	99.99	99.99	99.99	99.99	99.99	99.99
H13 HEPA filter area	Metric (m2)	1.2	1.2	2.4	2.4	3.6	3.6
	USCS (ft2)	13	13	26	26	39	39
Dust collection system	Type	Continuous folding bag	Continuous folding bag	Continuous folding bag	Continuous folding bag	Continuous folding bag	Continuous folding bag
Dimensions (L*W*H)	Metric (mm)	420x680x1100	420x680x1100	570x710x1270	570x710x1270	630x840x1470	630x840x1470
	USCS (inch)	16.5x26.7x43.3	16.5x26.7x43.3	22.4x28x50	22.4x28x50	24.8x33x57.8	24.8x33x57.8
Weight	Metric (kg)	30	30	48	48	65	65
	USCS (lbs)	67	67	107	107	145	145

TIV1000 230V

Packing list

TS1000

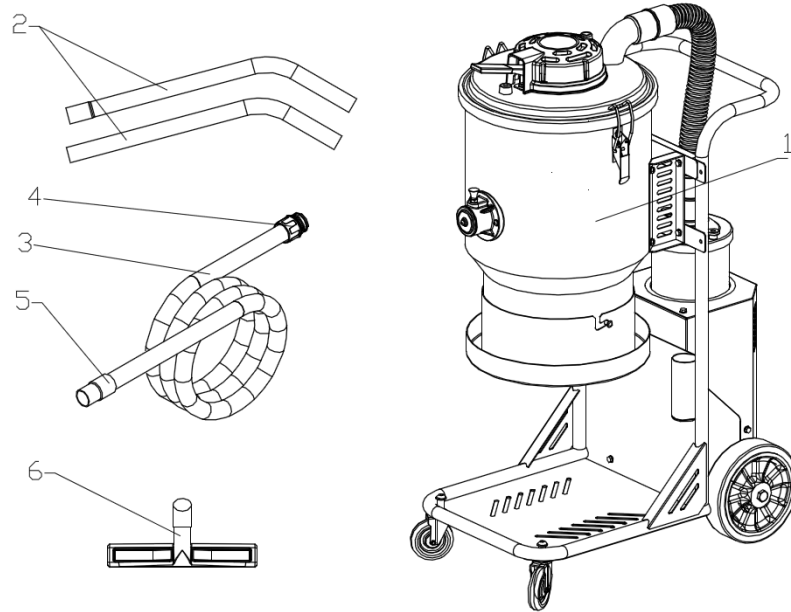

TS1000 machine & accessories

S/N	P/N	Description	Quantity	Unit
1		TIV1000 dust extractor	1	PC
2	S8025	D38 L wands	2	PC
3	S8023	D38 EVA hose	5	Meter
4	C3015	D38 hose cuff	1	PC
5	S8022	D38 connector	1	PC
6	S8019	D38 floor brush	1	PC

TIV1000 230V

Exploded views

TS1000

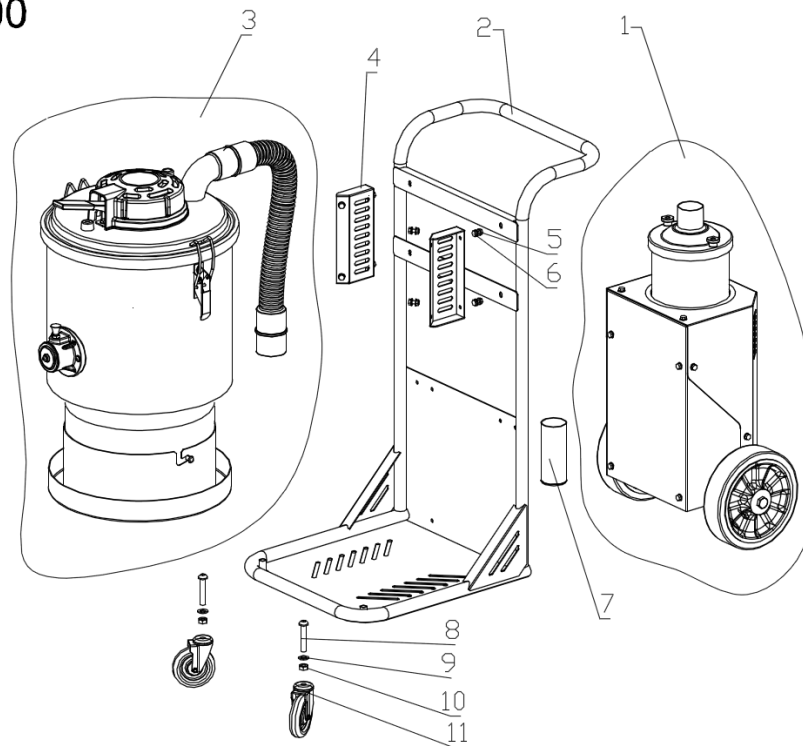

S/N	P/N	Description	Quantity	Dimension
1		Engine system kit	1	
2	C2139	TIV1000 wagon complete packing	1	
3		TIV1000 dustbin kit	1	
4	C2159	Connection plate	2	
5	S0010	Bolt	4	M6*12
6	S0011	Nut	4	M6
7	C2083	nylon cable tie storage container	1	
8	S0032	Bolt	2	M10*60
9	S0045	Plain cushion	2	M10
10	S0015	Locknut	2	M10
11	S9030	Front wheel	2	3''

TIV1000 230V

Dustbin kit

TS1000

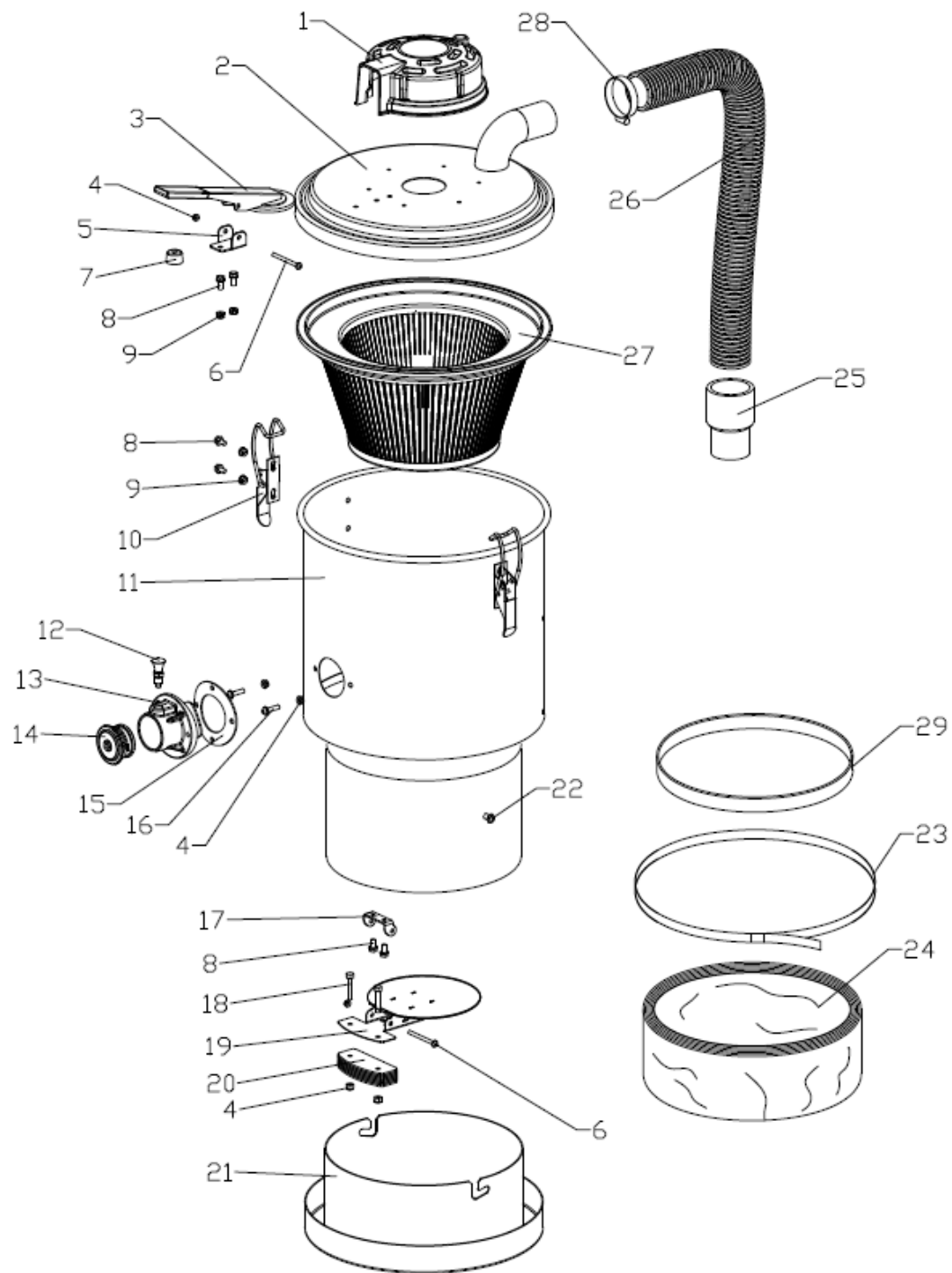

S/N	P/N	Description	Quantity	Dimension
1	C3026	Plastic cover	1	
2	C2119	TIV1000 top cap	1	
3	C2134	Lever (for jet pulse filter cleaning)	1	
4	S0013	Locking device packing	5	M6
5	C2057	Lever holder	1	
6	S0028	Bolt	2	M6*60
7	S0088	Cushion	1	
8	S0010	Bolt	6	M6*12
9	S0011	Nut	8	M6
10	S0059	Holder kit	2	
11	C2122	TIV1000 barrel	1	
12	C2022	Index plunger	1	
13	C3020	D50 inlet	1	
14	C3016	Inlet seal complete set packing	1	
15	C3017	Cushion for D50 inlet	1	
16	S0022	Bolt	2	M6*20
17	C2092	Holder	1	
18	S0023	Bolt	2	M6*35
19	C2090	Flap assembly kit	1	
20	C2091	../..../hp/AppData/Local/youdao/dict/Application/7.5.0.0/resultui/dict/?keyword=Balancing ../..../hp/AppData/Local/youdao/dict/Application/7.5.0.0/resultui/dict/?keyword=weight	6	
21	C2084	Continuous bag holder packing	1	
22	S0089	Nut	2	M8*15
23	S0090	Belt packing	1	
24	S8035	Continuous folding bag	1	
25	S8006	D50 ant static hose cuff	2	
26	S8007	D50 EVA anti static hose	1	D50*520mm
27	S8028	TIV1000 main filter	1	
28	S0092	Hose Clamp 40-63mm packing	1	40-63
29	S8036	Rubber ring	1	

TIV1000 230V

Engine kit

TS1000

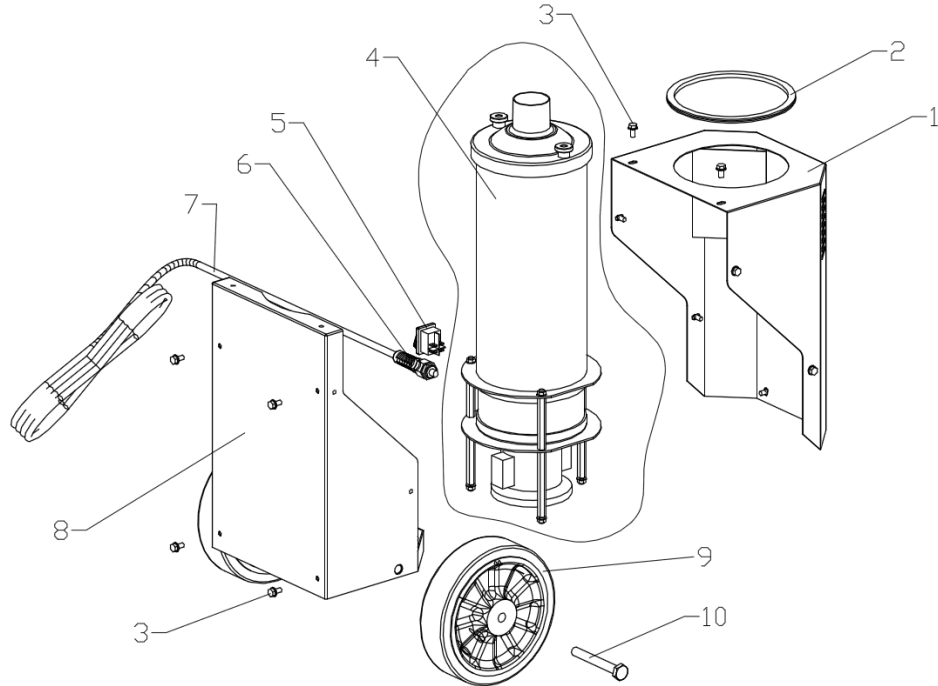

S/N	P/N	Description	Quantity	Dimension	Note
1	C2132	TIV1000 engine cover kit	1		
2	S9026	Rubber ring	1		
3	S0010	Nut	12	M6*12	
4		Motor kit	1		
5	S1001	Switch packing	1		
6	S0006	Connector	1	PG11	
7	S2005	Cable with electricity plug	1	3*1.5 8 meters length - RVV-10A electricity plug	240V
	S2006	Cable with electricity plug	1	3*2.0 8 meters length - RVV-US electricity plug	110V
8	C2129	TIV1000 engine packing	1		
9	S9009	Rear wheel	1	8''	
10	S0033	Nut	2	M12*100	

TIV1000 motor kit

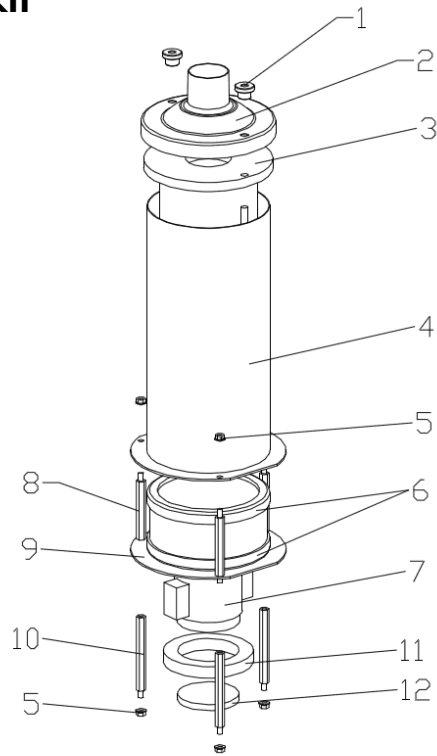

S/N	P/N	Description	Quantity	Dimension	Notes
1	S0091	Nut	2	M8	
2	C2115	HEPA filter top cover	1		
3	S8031	H13 HEPA filter	1		
4	C2116	HEPA filter cover	1		
5	S0011	Nut	6	M6	
6	C3007	Shock absorption rubber ring	2		
7	S1034	Single phase motor	1	240V 1000W	
	S1035	Single phase motor	1	120V 1200W	TS1100
	S1036	Single phase motor	1	120V 1000W	TS2100
	S1037	Single phase motor	1	120V 800W	TS3100
8	S0086	Screws-1	3	M6-76.5	
9	C2123	TS motor fixed plate	1		
10	S0087	Screws-2	3	M6-96.5	
11	S9028	Soundproof sponge	1	D98-78-15	
12	S9029	Filter cotton	1	D78-8	

Product: Vacuum Cleaner

Description:220-240V,50/60HZ

Model: TIV1000, TIV2000, TIV3000, TIV2500, TIV3500

Are in compliance with the following standards:

EN ISO 12100:2010

EN 60335-1:2012/A11:2014

EN 60335-2-69:2015

EN 61000-6-2:2005/AC:2005

EN 61000-6-4:2007/A1:2011

With reference to EC directive applied:

Machinery Directive 2006/42/EC

Electromagnetic Compatibility 2014/30/EU