

INTRODUCTION

Thank you for choosing Tornado Industrial Vacuum Cleaner, a high-quality product based on the newest state-of-the-art technology. We hope that this device will be to your satisfaction and meet your expectations. We are continuously striving to improve our products in our product segment and will continue to supply the market with new equipment.

NOTICE!

1. These instructions are only for the air scrubber B2000.
2. The air cleaner can only be used to collect dry, non-explosive materials. It is not suitable for picking up liquids.
3. Please pay particular attention to the safety regulations and safety instructions
4. Read the complete instruction manual before using.
5. All spare parts and accessories used with this device must be those specified by Tornado.
6. Check before and after use that all the switches are in OFF position.

Environmental protection

The packaging material can be recycled. Please do not throw the packaging material into household waste; please send it for recycling.

Old devices contain valuable materials that can be recycled; these should be sent for recycling. Batteries, oil, and similar substances must not enter the environment. Please dispose of your old devices using appropriate collection systems.

UNPACKING

When unpacking the machine, please check that the air cleaner has not been damaged in transport

1. SAFETY INSTRUCTIONS

When using an electrical appliance, basic precautions should always be followed, including the following:

WARNING – To reduce the risk of fire, electric shock or injury:

- Cables damaged through crushing or splitting can be dangerous if used and should be replaced immediately. Risk of personal injury.
- Do not connect the machine to an unearthed socket. Risk of personal injury
- Make sure the assembly area is firm, so the air cleaner does not tip over. Risk of personal and material injury.
- Risk of pinching when handling the toggle fastener.
- The machine must not be used in environments where explosive gases may be present. Serious risk of explosion
- The machine should be turned off at the switch before releasing the power lead from the wall outlet. If the switch is in the on position, a spark can occur between the contact on the power lead contact.
- Remove the plug from the wall socket when carrying out maintenance work. Risk of personal injury.
- Dust that is hazardous to health can be spread when the coarse filter and the absolute filter are replaced. Accordingly, the user should wear protective glasses, protective gloves, and a breathing mask conforming to protection class FFP2
- Do not puncture the absolute filter. Risk of dust dispersion.

SAFETY LABEL

The following label appears in front of the machine. Check all the details stated in the label before using. Replace label if it is missing, becomes damaged or illegible. Failure to follow this warning label may result in fire, electric shock or injury.

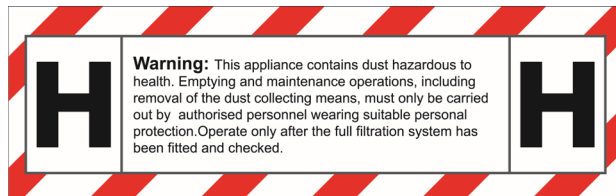

2. FUNCTION

Connect the power cord to the power outlet, attach the outlet hose if available. Start the machine by pressing the start knob.

The air cleaner has two speeds. The air cleaner separates material in two stages: The first stage uses a coarse filter. It captures the bigger particles and acts as protection for the main filter. The coarse filter should be changed on a daily basis. The second HEPA filter separates the unhealthy dust that is invisible to the eye.

Coarse filter characteristics

The coarse filter is strong and easy to change. It has low pressure drop and good separation capability. The coarse filter takes care of big particles and acts as protection for the absolute filter.

HEPA filter characteristics

The HEPA 13 filter is individually tested with efficiency [>99.97@0.3um](#). It is dimensioned for fine, dry dust and should be preceded by a pre-filter.

Caution

- The operating life of the absolute filter decreases and can be completely destroyed if exposed to water.

Caution

- The absolute filters cannot be cleaned and must be replaced when full

Filter indicator

B2000 has two filter indicators connected to a warning light which measures the pressure drop over the filter. If the pressure drop is too high, an orange lamp lights up, indicating that the filter is clogged and should be changed. Using the air cleaner when the warning light is showing will reduce the effectiveness of the machine. When the pressure drop is too low, a red lamp will light up, indicating that the HEPA filter is leaking/punctured and needs to be replaced immediately.

Fan

The air cleaner is equipped with a single, 1 phase fan

3. WARRANTY

All Tornado devices and accessories have a 12-month factory warranty counting from the manufacturing date on the machine. Do not attempt to repair the suction apparatus without the consent of the manufacturer.

The warranty does not cover defects which are the result of normal wear and tear, negligence, defective use, unauthorized repair or the suction apparatus being connected to the incorrect voltage.

In the event of any complaint, the suction apparatus or an agreed part of it must be returned to us or our authorized representative for warranty examination and for any warranty repair or replacement.

4. PROBLEM SOLVING

Issue	Cause	Solution
The fan doesn't start	No Power	Plug in machine
	Cable defective	Replace cable
	Switch defective	Replace switch
The fan stops immediately after starting	Wrong fuse	Connect the correct fuse
The fan runs, but suction is poor	Filter clogged	Replace filter
	Loose top cover	Adjust
	Sealing defect	Change current seal
Dust blown from motor	Defective or loose filter	Adjust/Replace filters
Abnormal noise		Order service

10. TECHNICAL DATA

Model	B2000
Power	610W
Voltage	230V
Current	2.9A
Power supply	1-phase
Airflow	2000 m3/h
Pre filter area	0.64m2
HEPA filter efficiency	H13, >99.97% @0.3um
HEPA Filter area	10.5 m2
Dimension	710X500X850mm
G.W	38kgs

Explosive view

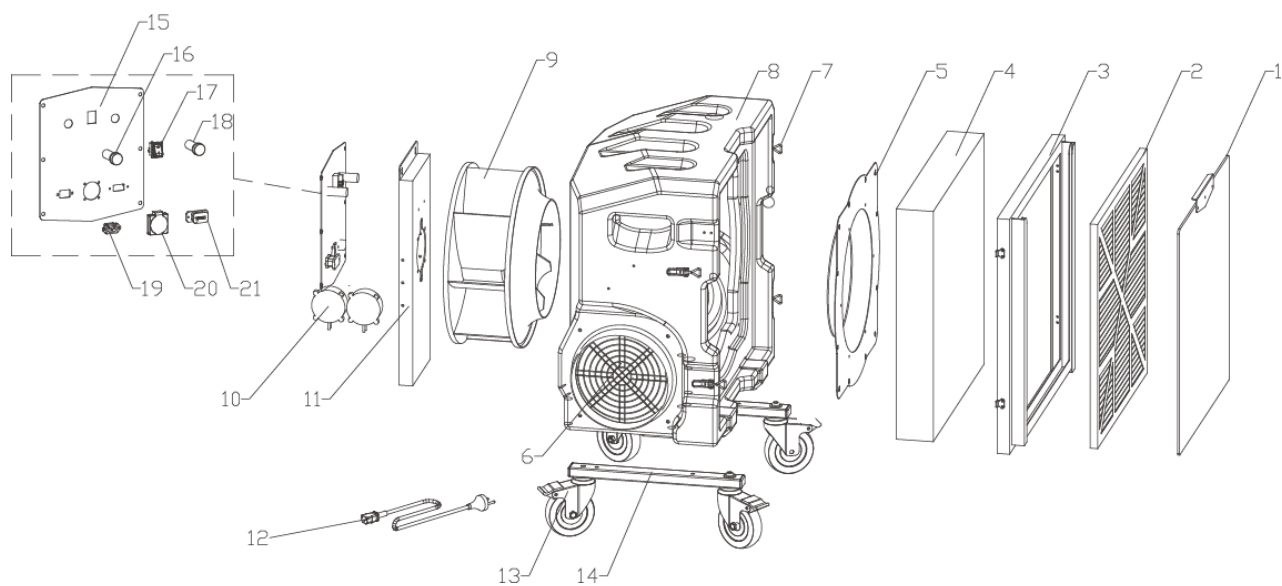

S/N	P/N	Description	Qty	Dimension	Note
1	S8065	B2000 Pre filter protect cover	1		
2	S8064	B2000 Pre filter	1		
3	C2326	B2000 Front frame cover	1		
4	S8063	B2000 Hepa filter	1		
5	C2328	B2000 inlet	1		
6	S9035	Protective net for outlet	1	250	
7	S9037	Buckle	4		
8	C3051	B2000 Frame carbinet	1		
9	S1056	Fan	1	450-600W	
10	S1057	Sensor	2		
11	C2327	B2000 fan fixed plate	1		
12	S2009	Power cord	1		
13	S9008	5'' universal caster	4	5''	
14	C2330	B2000 caster holder	2		
15	C2329	B2000 switch panel	1		
16	S1052	Sound alarm (Red lamp)	1		
17	S1054	Switch	1	15A,3 speeds	
18	S1053	Sound alarm(Orange lamp)	1		
19	S1055	Power outlet	1		
20	S1050	10A electrical outlet(for 230V version only)	1		
21	S1038	Hour meter	1		